

No. 771,821.

PATENTED OCT. 11, 1904.

S. GLEAZEN.  
PORTABLE DAM.  
APPLICATION FILED DEC. 16, 1903.

NO MODEL.

2 SHEETS—SHEET 1.

*Fig. 1.*

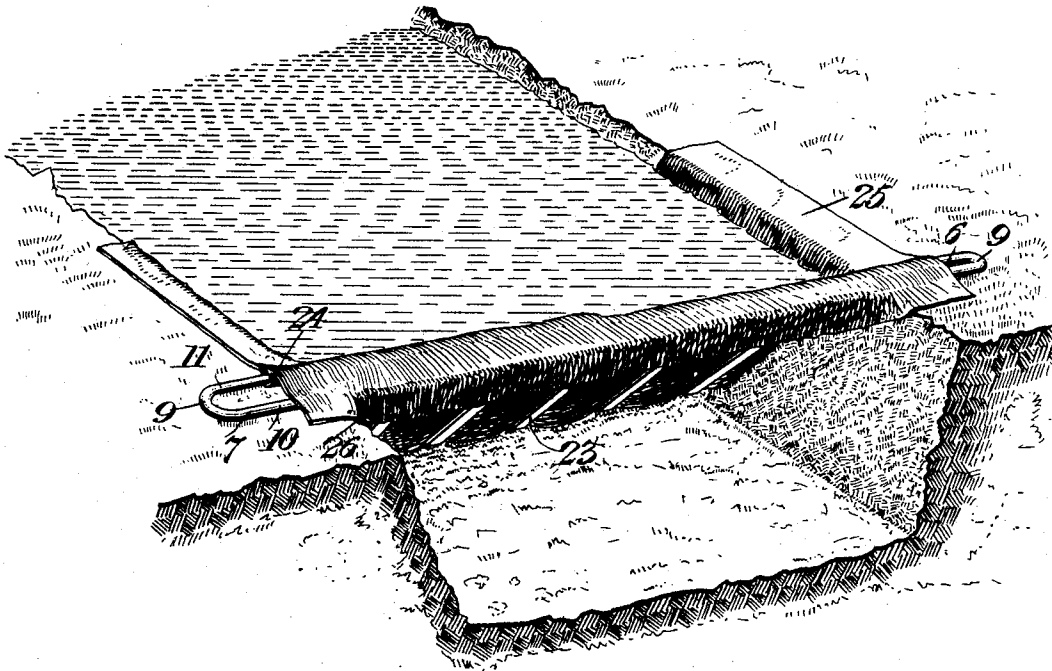

*Fig. 2.*

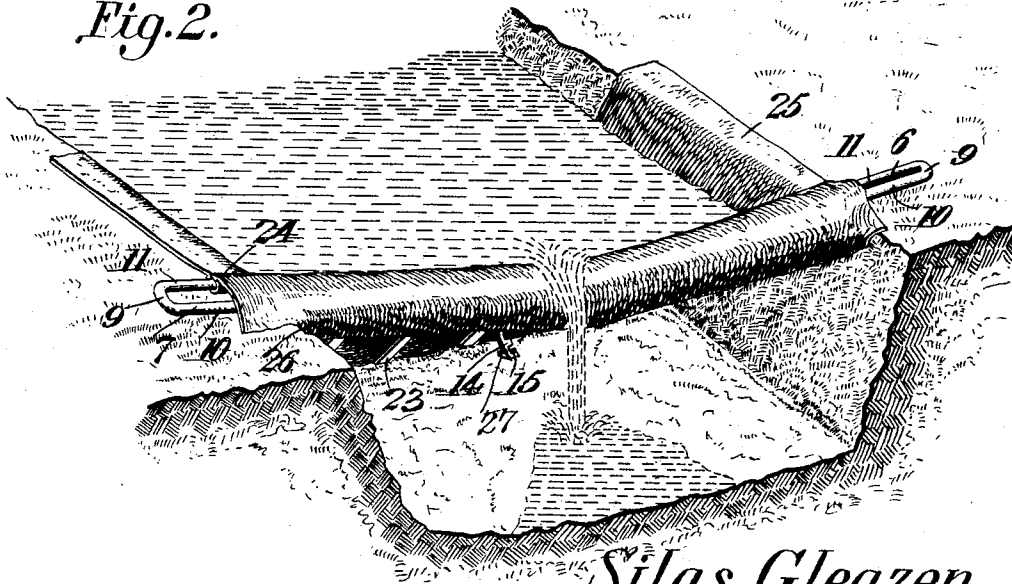

Witnesses  
*E. H. Stewart*  
*S. H. McKee*

*Silas Gleazen,*  
Inventor.  
by *C. A. Snow & Co.*  
Attorneys

No. 771,821.

PATENTED OCT. 11, 1904.

S. GLEAZEN.  
PORTABLE DAM.

APPLICATION FILED DEC. 16, 1903.

NO MODEL.

2 SHEETS—SHEET 2.

Fig. 3.

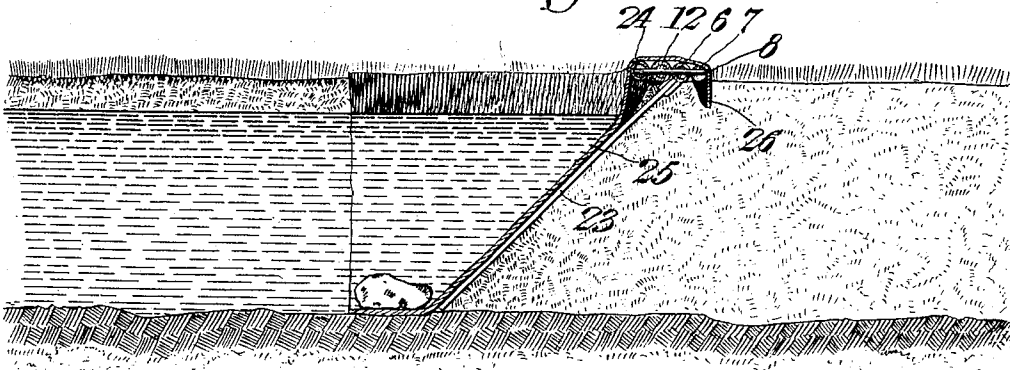
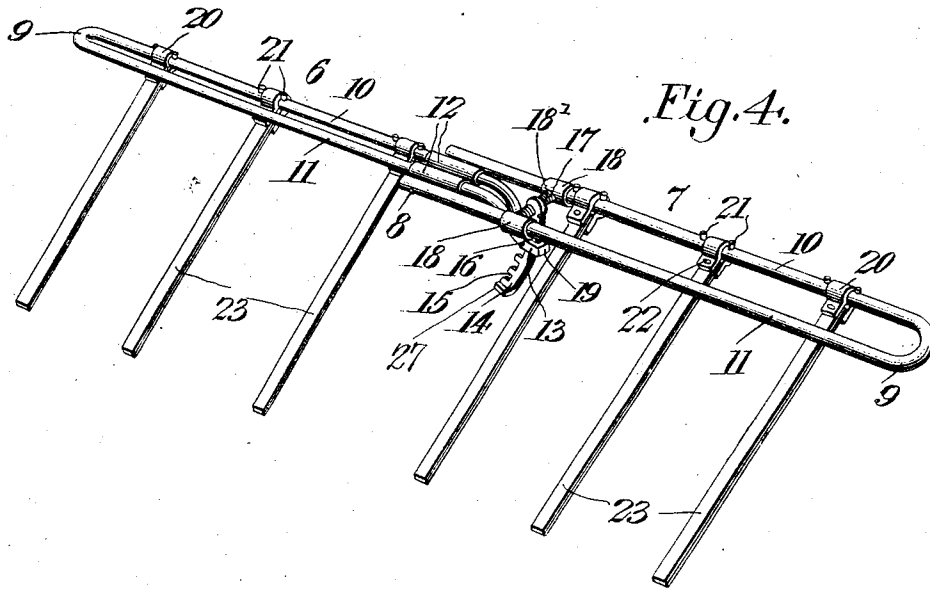

Fig. 4.



Witnesses  
*E. Stewart*  
*J. M. Allen*

*Silas Gleazen,*  
 Inventor.  
 by *C. Snowles*  
 Attorneys

# UNITED STATES PATENT OFFICE.

SILAS GLEAZEN, OF FORT COLLINS, COLORADO.

## PORTABLE DAM.

SPECIFICATION forming part of Letters Patent No. 771,821, dated October 11, 1904.

Application filed December 16, 1903. Serial No. 185,429. (No model.)

*To all whom it may concern:*

Be it known that I, SILAS GLEAZEN, a citizen of the United States, residing at Fort Collins, in the county of Larimer and State of Colorado, have invented a new and useful Portable Dam, of which the following is a specification.

This invention relates to an improved portable dam for use in irrigating ditches and other waterways, and has for its object to provide a simple, inexpensive, and efficient device of this character which when placed in position in the ditch or waterway will effectively stop the flow of water until the same has reached a predetermined height.

A further object of the invention is to provide means whereby the dam may be conveniently adjusted to accommodate ditches of different widths and to provide means for regulating the height of water in the ditch and means for controlling the discharge of the same upon the land to be irrigated.

A further object is to form the supporting-frame of the dam in such a manner as to effectively brace the apron-supporting arms, thereby preventing excessive bulging of the apron and accidental displacement of the same when the pressure of water becomes very great.

A still further object of the invention is to provide a dam capable of being quickly set up for use and which may be compactly folded, so as to permit the same to be readily transported from place to place.

The invention consists in the construction and novel combination and arrangement of parts hereinafter fully described, illustrated in the accompanying drawings, and pointed out in the claims hereto appended, it being understood that various changes in form, proportion, and minor details of construction may be resorted to without departing from the principle or sacrificing any of the advantages of this invention.

In the accompanying drawings, forming a part of this specification, and in which like numerals of reference indicate corresponding parts in all the figures, Figure 1 is a perspective view of a portion of a ditch or waterway, showing my improved dam in position therein. Fig. 2 is a similar view showing the dam

adjusted to permit the escape of a portion of the water. Fig. 3 is a vertical sectional view. Fig. 4 is a perspective view of the frame and supporting-bars with the apron detached.

In constructing the dam I preferably form the supporting-frame in two sections 6 and 7, pivoted together in any suitable manner, as by a pin or bolt 8. The sections 6 and 7 are each preferably formed of a single bar of metal or other suitable material bent on itself, as shown at 9, to form a pair of spaced parallel arms 10 and 11, respectively, the arms comprising the section 6 being provided with spacing-collars 12, which engage the adjacent ends of the section 7 and through which the pivot-pin 8 passes, as shown. The inner ends of the arms of the section 6 are bent downwardly to form a closed loop or keeper 13, adapted to receive a locking-segment 14, the notches 15 of which engage a pin 16, extending transversely across the keeper and by means of which the pivoted sections may be raised or lowered to regulate the flow of water over the dam.

The locking-segment 14 is pivotally mounted on a transversely-disposed rod 17, passing through collars 18 on the pivoted section 7, and mounted on said rod is a coiled spring 18', which normally holds the locking-segment in engagement with the pin 16, rearward movement of said segment being limited by the closed end 19 of the keeper 13. Loosely mounted on the arms 10 of the sections 6 and 7 are a series of supporting loops or straps 20, spaced apart at suitable intervals by means of threaded pins 21, which engage the bars on each side of said straps. Pivoted in any suitable manner between the ends of the straps 20, as by pins 22, are inclined apron-supporting bars 23, the upper end of each of which preferably rests against the arms 11 of the pivoted sections and the lower end thereof in contact with the ground, as clearly shown in Figs. 1 and 3 of the drawings. Passing over the arms 11 and secured thereto in any suitable manner, as by a row of stitching 24, is an apron 25, formed of canvas, rubber, or other material impervious to water, the lower end of which rests on the ground in advance of the bars 23, the upper end thereof being

extended beyond the securing means to form a flap 26. The flap 26 is designed to cover the space between the parallel arms of the two sections and protect the locking-segment from contact with the water when the same is discharged over the dam, as clearly shown in Fig. 3, said flap being held in position by the weight or pressure of the water. The free end of the locking-segment 14 is preferably formed with a laterally-extending lug or stop 27, which engages the side wall of the loop or keeper and prevents the segment from being entirely withdrawn from its keeper when the pivoted sections 6 and 7 are adjusted downwardly to their full extent.

In practice the ends of the supporting-bars 23 are first adjusted laterally to accommodate the width of the ditch and the dam placed in position with the ends of the pivoted sections resting on the banks of the stream, as clearly illustrated in Figs. 1 and 3 of the drawings. The height of the water in the stream above the dam, as well as the flow or volume of the water discharged over said dam, may be controlled by raising or lowering the pivoted sections and locking the same in the adjusted position by means of the locking-segment, as illustrated in Fig. 2, said segment being protected from the action of the water by the flap 26.

The frame of the dam being formed in two sections pivotally connected together, it is obvious that the same may be readily folded and conveniently carried from place to place.

From the foregoing description it will be seen that I have provided an exceedingly cheap, simple, and effective dam which may be quickly placed in position for use and compactly folded for transportation or shipment. Having thus described the invention, what is claimed is—

1. A dam comprising an apron, an apron-support, and means for vertically adjusting the intermediate portion of the support relatively to the ends thereof.

2. A dam comprising an apron, a pivotal apron-support, and means for vertically adjusting the intermediate portion of the support relatively to the ends thereof.

3. A dam comprising an apron, an apron-support provided with an intermediate hinged connection, and means for vertically adjusting the intermediate portion of the support relatively to the ends thereof.

4. A dam comprising an apron, an apron-support, a plurality of laterally-adjustable bars carried by the support, and means for vertically adjusting the intermediate portion of the support relatively to the ends thereof.

5. A dam comprising an apron, an apron-support, a plurality of laterally-adjustable bars pivotally mounted on the support and spaced from the apron, and means for vertically adjusting the intermediate portion of the support relatively to the ends thereof.

6. A dam comprising an apron-support and an apron one end of which is free and extends over and beyond the support to form a shield.

7. A dam comprising a support and an apron secured to the support and having one end thereof free and extended beyond the securing means to form a shield.

8. A dam comprising an apron, an apron-support, means for vertically adjusting the intermediate portion of the support relatively to the ends thereof, and means for locking the support in adjusted position.

9. A portable dam comprising an apron and an apron-support formed of a plurality of pivoted sections adapted to fold one on the other.

10. A dam comprising a support formed of a pair of spaced horizontally-disposed arms, an apron secured to one of the arms, and a plurality of laterally-adjustable bars mounted on the other.

11. A dam comprising a support formed of a pair of spaced horizontally-disposed arms, an apron secured to one of the arms, and a plurality of laterally-adjustable bars mounted on the opposite arm, said arms being provided with an intermediate pivotal connection.

12. A dam comprising a support formed of a pair of spaced arms, an apron secured to one of the arms, and a plurality of laterally-adjustable bars pivotally mounted on the other, means for vertically adjusting the intermediate portion of the support relatively to the ends thereof, and means for locking the support in adjusted position.

13. In a portable dam, a support formed in two sections pivoted at their inner ends, a locking-segment carried by one of said sections, a keeper formed in the opposite section and adapted to engage said segment, and an apron secured to the support.

14. In a portable dam, a support formed in two sections pivoted at their inner ends, a locking-segment carried by one of said sections, a keeper formed in the opposite section and adapted to receive the segment, means for holding the locking-segment in engagement with its keeper, and a flexible apron carried by the support.

15. In a portable dam, a support formed of a pair of spaced horizontally-disposed arms provided with an intermediate hinged connection, an apron carried by one of the arms, and a plurality of laterally-adjustable bars pivotally mounted on the opposite arm and adapted to engage the apron-carrying arm.

16. In a portable dam, a support formed of a pair of spaced horizontally-disposed arms provided with an intermediate hinged connection, an apron carried by one of said arms, straps or loops mounted on the opposite arm, pins secured to the arm on each side of the straps, bars pivoted to said straps, and means for vertically adjusting the support.

17. In a portable dam, a support formed in two sections pivoted at their inner ends, a locking-segment carried by one of said sections, a keeper formed in the opposite section, and  
5 a lug on the segment adapted to engage the keeper for limiting the pivotal movement of said sections.

18. A dam comprising an apron, an apron-support, a plurality of depending bars carried by the support, and means for vertically  
10 adjusting the intermediate portion of the support relatively to the ends thereof.

19. A dam including an apron and a support, the intermediate portion of the support being vertically adjustable with respect to the  
15 ends thereof.

In testimony that I claim the foregoing as my own I have hereto affixed my signature in the presence of two witnesses.

SILAS GLEAZEN.

Witnesses:

L. C. MOORE,  
F. B. KERRICK.